

SERIE C 500
SERIE C 600

Capacity kg 5000
Capacity kg 6000



DATI TECNICI	TECHNICAL DATA	TECHNISCHE DATEN	DONNÉES TECHNIQUES	DATOS TÉCNICOS		C500	C500D	C600	C600D
Portata max.	Max. capacity	Max. Tragfähigkeit	Capacité max.	Capacidad de carga máx.	kg	5000	5000	6000	6000
Portata max. sollevatore ausiliario	Max. auxiliary lift capacity	Max. Achsfreiheber-Tragfähigkeit	Capacité max. de l'élevateur auxiliaire	Capacidad de carga máx. elevador auxiliar	kg	-	4000	-	4000
Tempo di salita	Lifting time	Hubzeit	Temps de montée	Tiempo de subida	sec	66	66	70	70
Motore elettrico	Electric motor	Elektromotor	Moteur électrique	Motor eléctrico	Volt/Amp	230/400 - 12,9/7,5	230/400 - 15,3/8,9		
Potenza motore elettrico	Electric motor power	Motorleistung	Puissance du moteur électrique	Potencia motor eléctrico	KW-HP	2,2 / 3,0	2,2 / 3,0	2,6 / 3,5	2,6 / 3,5
Quantità d'olio necessaria	Required oil quantity	Ölfüllmenge	Quantité d'huile nécessaire	Cantidad de aceite que hace falta	l	24	27	24	27



Model Lift C 500 - C 500 D - C 600 - C 600 D

Model Lift C 500 - C 500 D - C 600 - C 600 D
(with on-Floor Installation)

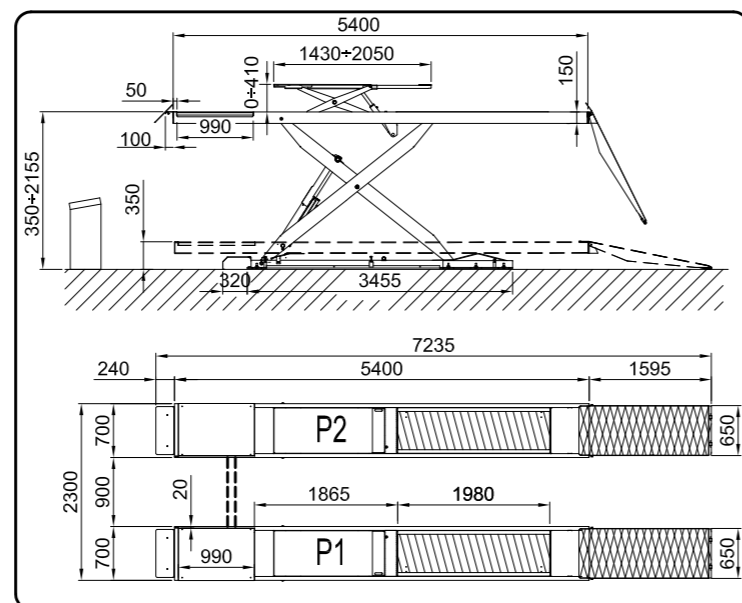
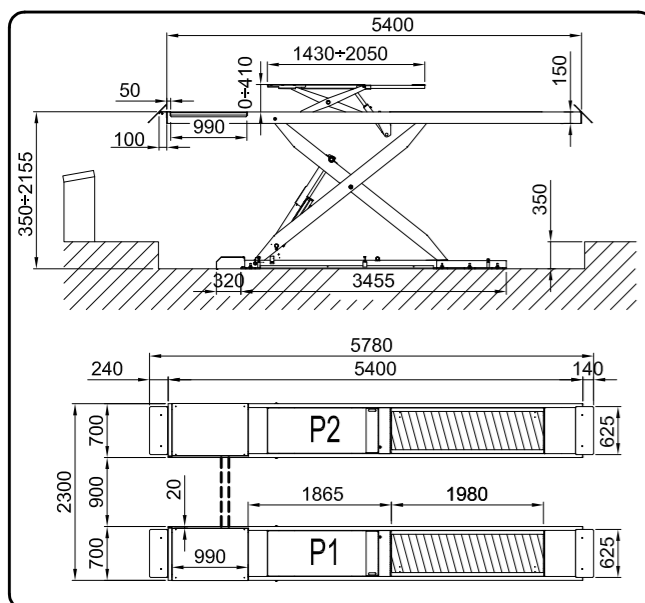

- A richiesta, installazione a pavimento con rampe di salita sollevabili.
- On demand, floor installation with raisable exit boards.
- Auf Wunsch: Montage auf Bodenhöhe mit anhebbaren Abfahrrampen.
- Sur demande, installation dans le sol avec des rampes de sorties éleables.
- A pedido, instalación en suelo con rampas de salida elevables.

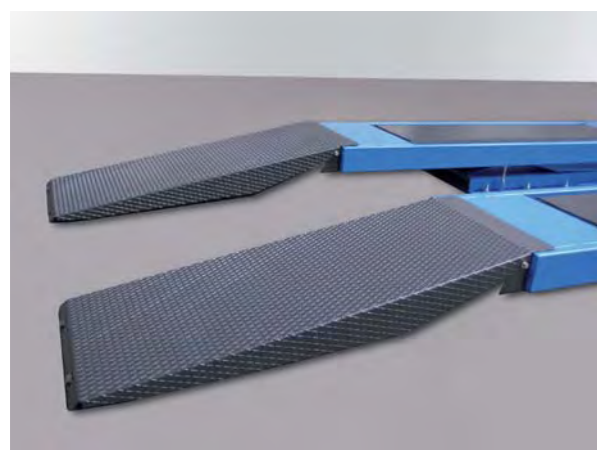

CE

SOLLEVATORE ELETTRIDRAULICO A FORBICE PER ASSETTO TOTALE
ELECTRO-HYDRAULIC SCISSOR LIFT FOR TOTAL WHEEL ALIGNMENT
ELEKTROHYDRAULISCHE SCHERENBÜHNE FÜR EINE KOMPLETTE AUSRICHTUNG
PONT ÉLEVATEUR HYDROÉLECTRIQUE À CISEAU POUR CENTRAGE TOTAL
ELEVADOR DE TIJERA ELECTROHIDRÁULICO PARA EQUIPAMIENTO TOTAL



AGM-COS.MET - srl
 Sede legale: Via Casette, 3/B Fraz. Almisano - 36045 LONIGO (Vicenza) Italy
 Destinazione merce e corrispondenza: Via Casette, 3/B Fraz. Almisano - 36045 LONIGO (Vicenza) Italy
 Tel. ++39 0444 720622 Fax ++39 0444 720623 http://www.agm-cosmet.com e-mail: agmcom@agm-cosmet.com

www.staggraphic.it Ed. 04/09

SERIE C 500 - C 600

Tutte le configurazioni C500-C600 sono state concepite e pensate al fine di realizzare un sollevatore per assetto totale dei veicoli e per soddisfare al massimo le esigenze dell'utilizzatore. La struttura e la forma delle pedane rendono facile qualsiasi modifica di configurazione anche dopo l'installazione.

All C500 – C600 configurations were conceived and ideated in order to realize a lift for a whole set-up of the vehicle, and to completely satisfy the user requirements. The structure and the shape of the platforms facilitate any modification of the configuration, even after the installation of the lift.

Alle C500-C600 Einstellungen wurden im Gedanken an eine Hebebühne entworfen, die eine vollständige Ausrichtung der Fahrzeuge möglich macht und den höchsten Ansprüchen ihres Benutzers genügt. Struktur und Form der Hebebühnen erlauben jegliche Änderungen der Einstellung, auch nach dem Zusammenbau.

Toutes les configurations C500-C600 ont été conçues et pensées dans le but de réaliser un élévateur pour l'ajustement total de véhicules et pour satisfaire au maximum les exigences de ceux qui l'utilise. La structure et la forme des plate-formes facilitent n'importe quelle modification dans la configuration, y compris après l'installation.

Todas las configuraciones C500-C600 fueron concebidas y pensadas con el fin de realizar un elevador para el ajuste total de vehículos y para satisfacer al máximo las exigencias de quien lo utiliza. La estructura y la forma de las plataformas facilitan cualquier modificación en la configuración, inclusive después de la instalación.

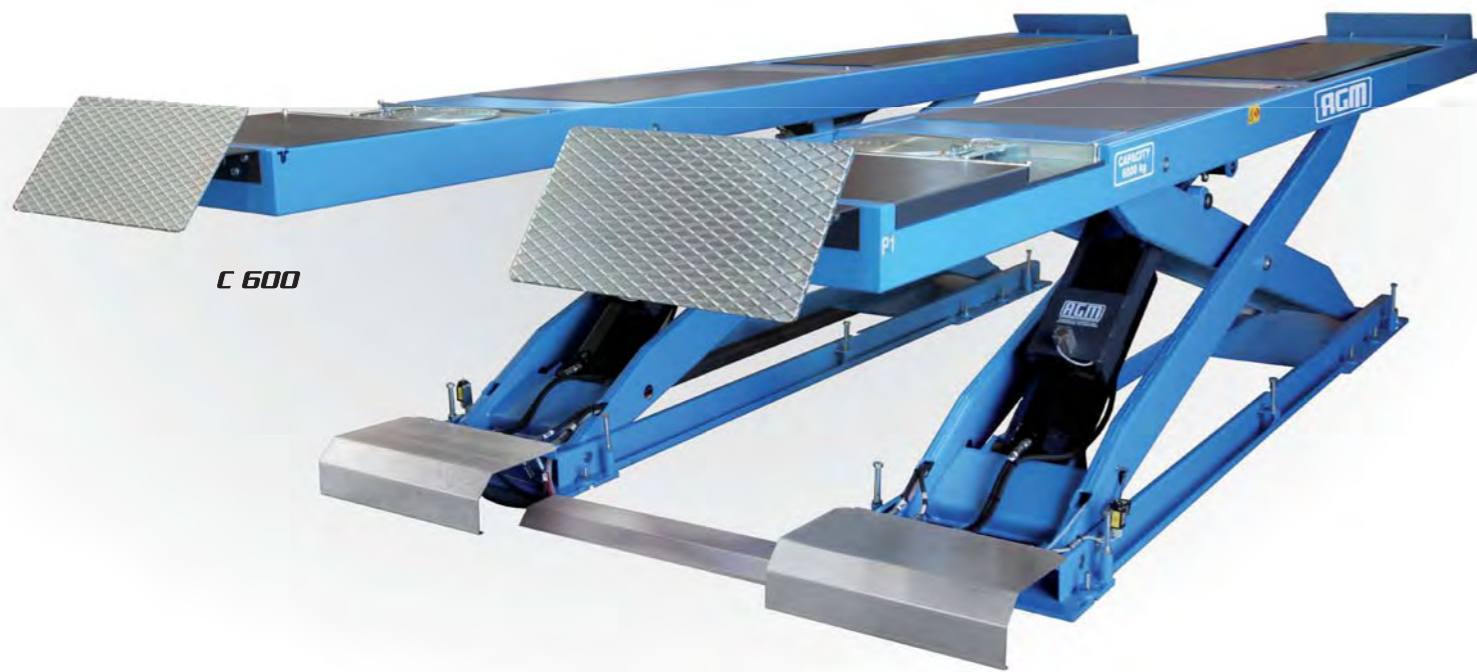

- Collegamento pedana-bracci di sollevamento con un unico perno passante.

- Piastre regolabili di grosso spessore per supporto Piatti Rotanti

- Dispositivo di sicurezza per anti-collisione Prolunga del sollevatore ausiliario.

- Base di grosso spessore con 8 viti di regolazione costruita in un unico blocco

- One only rotating shaft for the platform – lifting arms connection

- Thick adjustable plates for Rotating Plates support.

- Safety mechanism for anti-collision of extension cable of the auxiliary lift.

- Thick base with 8 adjustment screws built in one block.

- Verbindung Hebebühne-Greifarme aus einem einzelnen beweglichen Bauteil.

- Verstellbare, massive Stützplatten tragen die Drehteller.

- Anti-Kollisions Sicherheitsvorrichtung Verlängerung des Hilfsaufzugs.

- Massiver Sockel mit 8 Verstellerschrauben, gebaut aus einem Stück.

- Connection plate-forme bras d'élévateurs avec un seul boulon passante.

- Plaques réglables de grosse épaisseur pour supporter des plateaux tournants.

- Dispositif de sécurité anti-collision rallonge de l'ascenseur auxiliaire.

- Base de grosse épaisseur avec 8 tournevis de régulation construite en un bloc unique.

- Conexión plataforma-brazos de elevamiento con un único perno pasante.

- Placas regulables de grueso espesor para soportar platos rotantes.

- Dispositivo de seguridad anti-collision Alargue del elevador auxiliar.

- Base de grueso espesor con 8 tornillos de regulación construida en un único bloque.

Configurazione per modelli - Configurations for models: C 500 - C 600 / C 500 D - C 600 D

Config	Ref./ Sigla	Stand.	Option.	Description / Descrizione
A	E	x		RECESS TOTAL COVER - COPERTURA TOTALE VANO
	R		x	LIGHTING SYSTEM - SET LAMPADE ILLUMINAZIONE
B	E	x		CLOSING PLATE, 4 mm thickness - PIASTRA CHIUSURA spess. 4mm
	N		x	PLAY DETECTOR MOVING COVER - COPERT. MOBILE VANO PROVAGIOCHI
	P		x	ROTATING PLATES KIT - SET PIATTI ROTANTI
	R		x	LIGHTING SYSTEM - SET LAMPADE ILLUMINAZIONE
C	D	x		CLOSING PLATE, 4 mm thickness - PIASTRA CHIUSURA spess. 4mm
	M	x		REAR SLIDING PLATES - MECHAN. LOCKING - PIANI OSCILLANTI POSTER. - BLOCCO MECCAN.
	N		x	PLAY DETECTOR MOVING COVER - COPERT. MOBILE VANO PROVAGIOCHI
	P		x	ROTATING PLATES KIT - SET PIATTI ROTANTI
	Q		x	REAR SLIDING PLATES - PNEUM. LOCKING - PIANI OSCILLANTI - BLOCCO PNEUM.
D	B	x		FIXED PLATE, 8 mm thickness - PIASTRA FISSA spess. 8mm
	C	x		ADJUSTABLE PLATE, 4 mm thickness - PIASTRA REGOLABILE spess. 4 mm
	N		x	PLAY DETECTOR MOVING COVER - COPERT. MOBILE VANO PROVAGIOCHI
	O		x	ROTATING PLATES MOVING COVER KIT - COPERT. MOBILE VANO PIATTI ROT.
	P		x	ROTATING PLATES KIT - SET PIATTI ROTANTI
E	B	x		FIXED PLATE, 8 mm thickness - PIASTRA FISSA spessore 8mm
	C	x		ADJUSTABLE PLATE, 8 mm thickness - PIASTRA REGOLABILE spess. 8 mm
	M	x		REAR SLIDING PLATES - MECHAN. LOCKING - PIANI OSCILLANTI POSTER. - BLOCCO MECCAN.
	N		x	PLAY DETECTOR MOVING COVER - COPERT. MOBILE VANO PROVAGIOCHI
	O		x	ROTATING PLATES MOVING COVER KIT - COPERT. MOBILE VANO PIATTI ROT.
	P		x	ROTATING PLATES KIT - SET PIATTI ROTANTI
F	A	x		PLAY DETECTOR - PROVA GIOCHI
	H	x		FIXED COVER FOR TUNING PLATE RECESS - COPERTURA FISSA VANO PIATTI ROTANTI
	R		x	LIGHTING SYSTEM - SET LAMPADE ILLUMINAZIONE
G	A	x		PLAY DETECTOR - PROVA GIOCHI
	C	x		ADJUSTABLE PLATE, 8 mm thickness - PIASTRA REGOLABILE sp. 8 mm
	O		x	ROTATING PLATES MOVING COVER KIT - COPERT. MOBILE VANO PIATTI ROT.
	P		x	ROTATING PLATES KIT - SET PIATTI ROTANTI
	R		x	LIGHTING SYSTEM - SET LAMPADE ILLUMINAZIONE
H	A	x		PLAY DETECTOR - PROVA GIOCHI
	C	x		ADJUSTABLE PLATE, 8 mm thickness - PIASTRA REGOLABILE sp. 8 mm
	M	x		REAR SLIDING PLATES - MECHAN. LOCKING - PIANI OSCILLANTI POSTER. - BLOCCO MECCAN.
	O		x	ROTATING PLATES MOVING COVER KIT - COPERT. MOBILE VANO PIATTI ROT.
	P		x	ROTATING PLATES KIT - SET PIATTI ROTANTI
	Q		x	REAR SLIDING PLATES - PNEUM. LOCKING - PIANI OSCILLANTI - BLOCCO PNEUM.
I	A	x		PLAY DETECTOR - PROVA GIOCHI
	C	x		ADJUSTABLE PLATE, 8 mm thickness - PIASTRA REGOLABILE sp. 8 mm
	G	x		FIXED COVER FOR PLAY DETECTOR - COPERTURA FISSA VANO PROVAGIOCHI
	O		x	ROTATING PLATES MOVING COVER KIT - COPERT. MOBILE VANO PIATTI ROT.
	P		x	ROTATING PLATES KIT - SET PIATTI ROTANTI
L	C	x		ADJUSTABLE PLATE, 8 mm thickness - PIASTRA REGOLABILE, sp. 8 mm
	G	x		FIXED COVER FOR PLAY DETECTOR - COPERTURA FISSA VANO PROVAGIOCHI
	M	x		REAR SLIDING PLATES - MECHAN. LOCKING - PIANI OSCILLANTI POSTER. - BLOCCO MECCAN.
	O		x	ROTATING PLATES MOVING COVER - COPERT. MOBILE VANO PIATTI ROT.
	P		x	ROTATING PLATES KIT - SET PIATTI ROTANTI
	Q		x	REAR SLIDING PLATES - PNEUM. LOCKING - PIANI OSCILLANTI - BLOCCO PNEUM.